

perma Lubrication Systems for  
**Blowers & Fans**



The World of Automatic Lubrication

**perma**<sup>®</sup>





## Trouble-free operation with automatic lubrication systems from perma

Productivity, equipment reliability and workplace safety are directly linked to key performance indicators of blowers and fans. This makes efficient maintenance of machines and equipment extremely important to plant operators. Numerous grease points on blowers and fans must be lubricated regularly at short intervals. Due to difficulties associated with access or safety during operation, it is common for some equipment to receive inadequate lubrication. This results in lubrication starvation, contamination entry and accelerated wear. Extreme operating conditions and limited labor resources call for reliable and tough lubrication equipment in order to prevent costly machine downtime.

Automatic lubrication systems from perma are successfully being used on blowers and fans worldwide. They are economical, meet technical demands and improve workplace safety.

## → Challenges

### Common blower and fan lubrication problems

During normal operation it is extremely difficult to shut down equipment to manually lubricate blowers and fans.

- **High risk of accidents!**
- **Bearing damages caused by incorrect lubrication!**
- **Blower and fan failures stop all following processes!**



Manufacturer recommended lubrication intervals for blowers and fans are very labor intensive and often impractical, but incorrect lubrication causes bearing damage of drive motors or fan shafts.

- **Costly repairs and equipment downtime as a result of premature wear!**



Re-lubrication work carried out in dangerous or hard to access places exposes maintenance staff to high safety risks.

- **High risk of workplace accidents!**



### Lubrication points on blowers and fans:

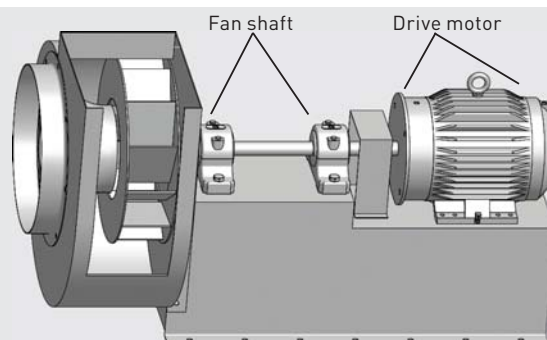

Fan drive shaft lubrication  
(2 points)

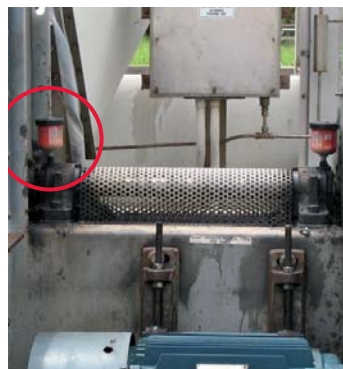

Drive motor lubrication  
(2 points)



Electric motor lubrication  
(please refer to flyer)



# → Solutions

## perma CLASSIC / perma FUTURA

- Housing: perma CLASSIC - metal / perma FUTURA - transparent plastics
- Electrochemical / grease and oil
- Operating temperature 0 °C to +40 °C
- Discharge period at 20 °C with SF01: 1, 3, 6 or 12 months
- Pressure build-up: Max. 4 bar
- Lubricant volume: 120 cm<sup>3</sup>



## perma NOVA

- Housing: Transparent plastics
- Electrochemical / grease and oil / temperature independent
- Operating temperature -20 °C to +60 °C
- Discharge period: 1, 2, 3,...12 months
- Pressure build-up: Max. 6 bar
- Lubricant volume: 130 cm<sup>3</sup>



## perma STAR product range

- Housing: Transparent plastics
- Electromechanical / grease and oil / temperature independent
- Operating temperature -10 °C to +50 °C
- Discharge period: 1, 3, 6, 12 months or machine controlled
- Pressure build-up: Max. 5 bar
- Lubricant volume: 60 cm<sup>3</sup>, 120 cm<sup>3</sup>, 250 cm<sup>3</sup>



## perma PRO product range

- Housing: Metal / transparent plastics
- Electromechanical / grease and oil / temperature independent
- Operating temperature -20 °C to +60 °C
- Discharge period: 1 day to 24 months or machine controlled
- Pressure build-up: Max. 25 bar
- Lubricant volume: 250 cm<sup>3</sup>, 500 cm<sup>3</sup>
- Number of lubrication points: 2-6

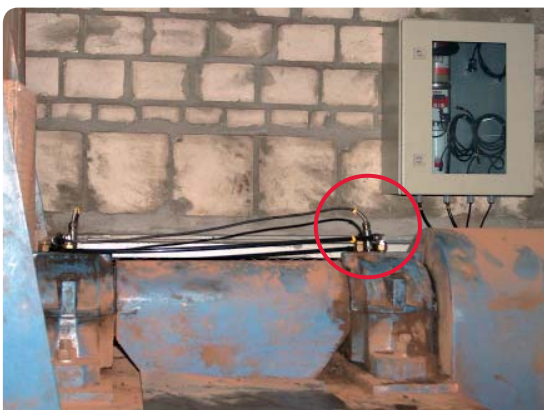

Lubrication system:  
perma PRO MP-6 (4 outlets activated)



Lubrication system:  
2 x perma STAR VARIO 250 cm<sup>3</sup>



Lubrication system:  
2 x perma STAR VARIO 120 cm<sup>3</sup>

## → Benefits

- Reduced premature wear
- Less equipment downtime
- Improved workplace safety

Product characteristics	Advantages	Benefits
<b>economical aspects</b>		
<b>perma CLASSIC / FUTURA</b> Fully automatic and reliable single-point lubrication at low cost → Simple activation with activator screw	<ul style="list-style-type: none"> <li>- Reliable bearing lubrication for normal ambient temperatures</li> <li>- Hands-free supply of fresh, clean lubricant</li> <li>- Works under water</li> </ul>	<ul style="list-style-type: none"> <li>- Reduced maintenance costs</li> <li>- Higher equipment availability</li> <li>- Easy to install and use</li> <li>- Reliable controlled lubrication</li> </ul>
<b>perma STAR / NOVA / PRO</b> Variable discharge periods → Exact discharge Separate drive unit	<ul style="list-style-type: none"> <li>- Precise and customized discharge</li> <li>- Ideal for high grade lubricants</li> <li>- Reusable drive unit</li> </ul>	<ul style="list-style-type: none"> <li>- Less equipment downtime, lower maintenance costs</li> <li>- Optimized lubrication saves lubricant and reduces material costs</li> <li>- Short ROI due to reduced follow-up costs</li> </ul>
<b>perma PRO product range</b> → Multi-point lubrication systems	<ul style="list-style-type: none"> <li>- One lubrication system can lubricate up to 6 lubrication points</li> </ul>	<ul style="list-style-type: none"> <li>- Saves time</li> <li>- Reduces maintenance costs</li> </ul>
<b>technical aspects</b>		
<b>perma FUTURA / NOVA</b> → Transparent, non-corrosive plastic housing	<ul style="list-style-type: none"> <li>- Meets hygienic and environmental regulations</li> </ul>	<ul style="list-style-type: none"> <li>- Can be used in areas which are hygienically sensitive</li> </ul>
<b>perma STAR product range</b> → Battery operated or machine controlled 3 different sizes / LED alert system	<ul style="list-style-type: none"> <li>- Fast, safe mounting at exposed places possible</li> <li>- Monitoring of lubricator via LEDs</li> </ul>	<ul style="list-style-type: none"> <li>- Reliable lubrication at hard to access lubrication points / simple retro-fitting</li> <li>- Reduces costly repairs</li> </ul>
<b>perma PRO product range</b> → Battery operated or machine controlled Display with push button control	<ul style="list-style-type: none"> <li>- System does not shut down if one or more grease points become blocked</li> <li>- Simple configuration</li> <li>- Function control via display</li> </ul>	<ul style="list-style-type: none"> <li>- Increases blower and fan service life</li> <li>- Lubrication of critical equipment can be easily monitored</li> </ul>
<b>workplace safety aspects</b>		
<b>perma CLASSIC / NOVA / FUTURA</b> → Ex-proof certification	<ul style="list-style-type: none"> <li>- Can be used in areas where explosive atmospheres may occur</li> </ul>	<ul style="list-style-type: none"> <li>- Save and reliable lubrication in dangerous areas</li> </ul>
<b>perma STAR product range</b> Pressure build-up: 5 bar max. <b>perma PRO product range</b> → Pressure build-up: 25 bar max.	<ul style="list-style-type: none"> <li>- Lubrication systems can be installed away from dangerous or hard to access lubrication points (perma STAR: grease lines up to 3 m perma PRO: grease lines up to 5 m)</li> </ul>	<ul style="list-style-type: none"> <li>- Tremendously reduces the risk of accidents</li> <li>- Increases workplace safety</li> </ul>

## perma lubrication systems for blowers and fans

Cooling, heating, process ventilation - blowers and fans are an integral part of most industries. From cement or power plants to the petrochemical industry, blowers and fans are required everywhere for the continuous flow of air or gas.

Since 1964, perma-tec has sold over 45 mill. lubrication systems. perma products are used in all types of industries worldwide for the lubrication of fans and blowers. They guarantee reliable automatic re-lubrication and process safety for all types of applications.

## perma automatic lubrication systems - we meet your needs:

- 24-hour operation
- Simple installation
- Easy tool-free exchange
- Requires little mounting space
- Tough systems: battery operated or machine controlled
- Customized supply of fresh lubricants to lubrication points

## perma is the most trusted partner worldwide for all industries:

- Global market leader for automatic single-point lubrication systems
- Largest product range in the market
- Many well-known satisfied customers
- Field-tested accessories for every perma lubrication system
- Product training, expert advice and consultation  
(please contact your local supplier)



## Applications for perma products

Bagging equipment

Electric motors

Transport systems

Sliding guides

Belt pretensioners

Chain drives

Paint finishing systems

Linear drive systems

Mills/crushers

Open gears

Presses

Escalators

Storage equipment

Silos

Ventilation systems

Pumps

### Do you have any questions about perma products for blowers or fans?

Please visit our website or contact your local supplier. We will gladly send you our extensive catalog for more detailed information.

**perma-tec GmbH & Co. KG**  
Hammelburger Str. 21  
97717 EUERDORF  
GERMANY

[info@perma-tec.com](mailto:info@perma-tec.com)  
[www.perma-tec.com](http://www.perma-tec.com)